

TO-220-3L Plastic-Encapsulate Transistors

FEATURES

- Medium Power Linear Switching Applications
- Complement to TIP41/41A/41B/41C
- TRANSISTOR (PNP)

MECHANICAL DATA

- Case style:TO-220-3L molded plastic
- Mounting position:any

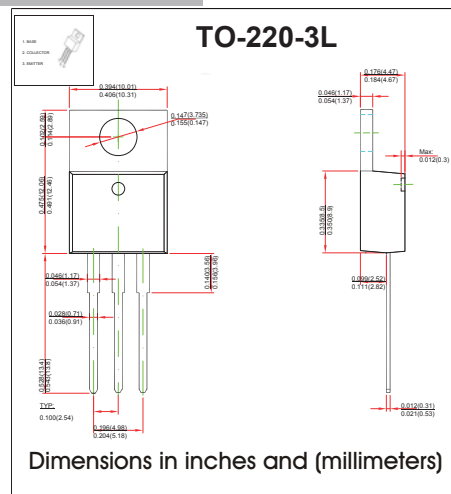

MAXIMUM RATINGS AND CHARACTERISTICS

@ 25°C Ambient Temperature (unless otherwise noted)

Symbol	Parameter	TIP42	TIP42A	TIP42B	TIP42C	Unit
V_{CB0}	Collector-Base Voltage	-40	-60	-80	-100	V
V_{CEO}	Collector-Emitter Voltage	-40	-60	-80	-100	V
V_{EBO}	Emitter-Base Voltage	-5				V
I_C	Collector Current -Continuous	-6				A
P_C	Collector Power Dissipation	2				W
T_J	Junction Temperature	150				°C
T_{stg}	Storage Temperature Range	-55to+150				°C

Parameter	Symbol	Test conditions	Min	Max	Unit
Collector-base breakdown voltage	TIP42 TIP42A TIP42B TIP42C $V_{(BR)CBO}$	$I_C = -1mA, I_E = 0$	-40 -60 -80 -100		V
Collector-emitter breakdown voltage	TIP42 TIP42A TIP42B TIP42C $V_{(BR)CEO}^*$	$I_C = -30mA, I_B = 0$	-40 -60 -80 -100		V
Emitter-base breakdown voltage	$V_{(BR)EBO}$	$I_E = -1mA, I_C = 0$	-5		V
Collector cut-off current	TIP42 TIP42A TIP42B TIP42C I_{CBO}	$V_{CB} = -40V, I_E = 0$ $V_{CB} = -60V, I_E = 0$ $V_{CB} = -80V, I_E = 0$ $V_{CB} = -100V, I_E = 0$		-0.4	mA
Collector cut-off current	TIP42/42A TIP42B/42C I_{CEO}	$V_{CE} = -30V, I_B = 0$ $V_{CE} = -60V, I_B = 0$		-0.7	mA
Emitter cut-off current	I_{EBO}	$V_{EB} = -5V, I_C = 0$		-1	mA
DC current gain	$h_{FE(1)}$	$V_{CE} = -4V, I_C = -0.3A$	30		
	$h_{FE(2)}$	$V_{CE} = -4V, I_C = -3A$	15	75	
Collector-emitter saturation voltage	$V_{CE(sat)}$	$I_C = -6A, I_B = -0.6A$		-1.5	V
Base-emitter voltage	V_{BE}	$V_{CE} = -4V, I_C = -6A$		-2	V
Transition frequency	f_T	$V_{CE} = -10V, I_C = -0.5$	3		MHz

*Pulse test

■ Typical Characteristics

